

销售电话 +86 734-8323019  
Sale Dept TEL +86 15073424261

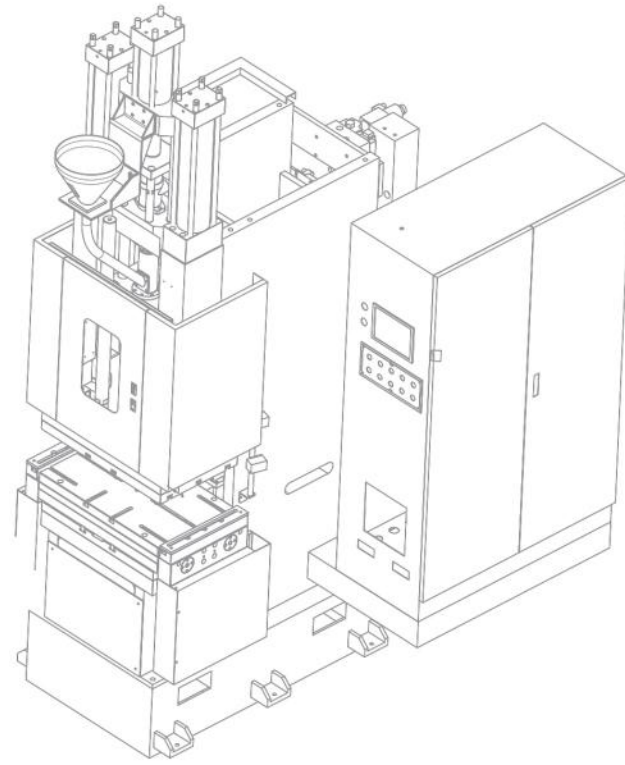

## Concentrate on rubber injection molding solution since 2001

专注橡胶注射成型解决方案20余年

**衡阳华意机械有限公司**  
Hengyang Huayi Machinery Co., Ltd

地 址: 湖南省衡阳市珠晖区苗圃街象山村1号  
传 真: 0734-8323002  
网 址: [www.huayijx.com](http://www.huayijx.com)  
[www.hwayimachine.com](http://www.hwayimachine.com)  
客服中心: 0734-8323000 0734-8323019

湖南省衡阳市白沙洲工业园工业大道1号  
邮 编: 421002/421007  
电子邮件: [huayijx@huayijx.com](mailto:huayijx@huayijx.com)



ADD1: No.1 MiaopuStreet, XiangshanVillage, HengyangCity, HunanProvince, China.  
ADD2: No.1 Industry Road, Baishazhou Industry Area, Hengyang City, Hunan Province, China.  
TEL: +86 734-8323019 FAX: +86 734-8323002 POST CODE: 421002/421007  
WEBSITE: [www.huayijx.com](http://www.huayijx.com) E-MAIL: [huayijx@huayijx.com](mailto:huayijx@huayijx.com)  
[www.hwayimachine.com](http://www.hwayimachine.com) [info@hwayimachine.com](mailto:info@hwayimachine.com)

**衡阳华意机械有限公司**  
Hengyang Huayi Machinery Co., Ltd

HENGYANG • CHINA



# COMPANY PROFILE

## 公司简介

## CONTENTS 目录

衡阳华意机械有限公司是一家香港投资的湖南省高新技术企业，创建于2001年3月18日，占地200余亩，厂房面积50000平米，全面通过ISO9001:2015质量管理体系认证；目前是国内专业从事橡胶注射成型机、抽真空平板硫化机、橡胶注射成型的最具规模的生产厂家之一；是多次承担国家火炬计划项目、国家创新基金项目的实施企业；产品的核心技术多项获得国家发明专利并具有独立的知识产权，现已广泛应用在电力电器、高压输变电、汽车橡胶零部件、铁路基础建设及机械密封件等行业。

Hengyang Huayi Machinery Co., Ltd., a Hong Kong invested high-tech enterprise, located in Hunan Province, who have concentrated on rubber injection machines R&D since 2001. We are one of the top manufacturer of rubber injection molding machine and vulcanizing press with excellent R&D ability and largest production capacity in China. Since Huayi company built, we have been the national torch plan project and the national innovation fund project implementation enterprise for many times, and our core technology has obtained more than 20 international invention patents and specific independent intellectual property rights. We keep optimizing the machine structure, hydraulic system, electrical controlling system to improve machine stability and long-life time by using world famous electrical components from Germany, France Japan or other world famous brands, and have tightly cooperation with Siemens, B&R, Rexroth, Yuken to make sure all the elements and manufacturing are strictly controlled. Now our machines are widely used in automotive rubber parts, railway infrastructure and mechanical seals, electric power, high voltage transmission, and other industries.



### 企业文化篇 COMPANY CULTURE

Company Profile

公司介绍

Company Achievements

公司荣誉

Team Style

团队风采

Production Area

生产车间

### 企业产品篇 PRODUCTS

Rubber Injection Molding Machine

橡胶注射成型机

LSR Clamping Machine

液态硅胶锁模机

Rubber Vulcanizing Press

橡胶平板硫化机

Special Design Machine

特殊定制机

De-Molding Mechanism

脱模装置

# COMPANY ACHIEVEMENTS

## 公司荣誉

# TEAM STYLE

## 团队风采



- ◆ 大型注射成型机发明专利 Large injection molding machine invention patent
- ◆ 橡胶注射成型机发明专利 Rubber injection molding machine invention patent
- ◆ 冷流道板多嘴注压橡胶装置 CRB multi-nozzles injection device
- ◆ 超长复合绝缘制品的组合模框式模具实用新型专利  
Practical new-type patent of combination mould style for composite insulation products
- ◆ ISO9001:2015 质量管理体系认证 ISO9001:2015 certification

### 力量来自凝聚

诚信 团结 开放 创新

Power Comes From Unity  
Honesty Solidarity Openness Innovation

- 诚信:** 信守承诺 言行合一 用心做好每一件事
- 团结:** 团队合作 有效沟通 目标统一
- 开放:** 广博胸怀 包容和谐 开放共赢
- 创新:** 凝集精华 融入新意 追求卓越 创造完美

- Honesty:** Keep Promise, Deeds Accord With Words, Care to Do Anything
- Solidarity:** Teamwork, Effective Communication, Uniform Goal
- Openness:** Broad Mind, Tolerance&Harmony, Win-win Openness
- Innovation:** Cohere Elite, Integrate Creation, Pursue Excellence, Create Perfection

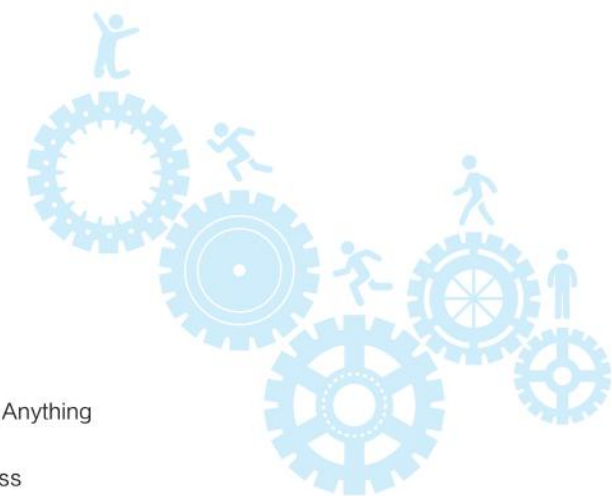

# PRODUCTION AREA 生产车间



### 1. Professional products

12 series products: Rubber injection molding machine, transfer press, vacuum compression molding machine and mould etc. More than seventy models are widely used in many fields of rubber products.

### 2. Professional team

Huayi's R&D team is composed with Doctors, Masters and senior engineers. They specialized in machinery, hydraulics, electricity, automation, software programming, chemistry analysis on polymer structure etc.

### 3. Professional spirit

Every Huayi people treat details rigorously, scientifically and seriously. Our services are sincerely, passionately and meticulously each time. To make the professional products with above spirit. Using professional spirit makes professional products.

## 研发在创新中超越

### 1、专业产品

橡胶注射成型机、注压机、抽真空平板硫化机、模具等十二大系列，七十多种规格型号，广泛涉及橡胶制品各个领域。

### 2、专业人员

拥有博士、硕士、高级工程师专职研发队伍。专业人员知识涵盖机械、液压、电器、自动控制、软件编程、高分子结构化学分析等，确保能研发出知名品牌的產品。

### 3、专业精神

每一位华意人对待细节都是严谨、科学、认真的，对待每一次的服务都是真诚、热情、细致的，以专业的精神去塑造专业的产品。



## 生产质量方针： 专心专业谋质量，锐意改进求满意

拥有先进的橡胶注射成型机、抽真空平板硫化机及橡胶注射模具装配生产线；拥有先进的零部件检测设备与工具；拥有高、精、尖、超大型自动编程加工中心、数控铣床、龙门刨床等机械加工设备数十台。

Huayi owns advanced production and assembly lines of rubber injection molding machine, vacuum compression molding machine and rubber injection mould; advanced inspection equipment and tools; more than 10 advanced, precise and super large processing equipments: processing center, CNC milling machine and double housing planer etc.

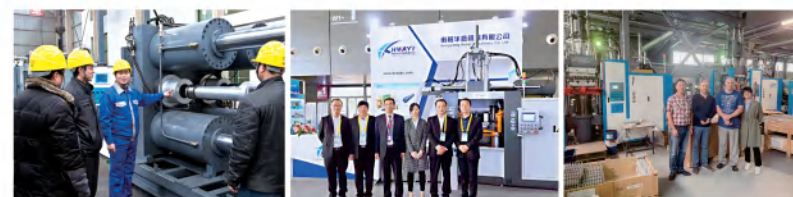

## 服务：售前 售中 售后

只有站在用户的角度为用户着想，才能赢得市场。

华意始终坚持以用户最终利益为目标，确定以服务为主导的理念，全方位、多层面向用户提供“全程无忧”的星级服务，从售前、售中到售后，用户都可以随时获得华意的支持。

To win the market only if we consider on the customer's point of view. Huayi always adheres to the customer's ultimate interests as the goal and the customer service experience as the philosophy, we provide our customers with complete and multi-level worry-free service. Customers can get technical support from us at any time.



## 物流：服务客户 超越期望

拥有专业的物流服务提供商，为广大用户提供专业、高效、品质的物流服务，可以根据您的需求为您量身定做产品物流解决方案，解决您的所有后顾之忧。

同时配备专属的物流团队，监管设备运输过程，保证设备安全和服务质量。

Cooperation with professional logistics service suppliers, providing the professional, efficient and high-quality service; we could also provide logistics solution according to our customers' requirement and solve all their worries. Meanwhile, we also supervise the whole process of transportation to ensure the safety arrival of equipments.

■ A Series Rubber Injection Molding Machine  
A 系列橡胶注射成型机



Machine Characteristics  
机器特点

- ◆ Four-column vertical structure ensures machine durability;
- ◆ Multi phases injection pressure and speed adapts multi molds production;
- ◆ Sturdy design of clamping unit for high stability and parallelism;
- ◆ Siemens or fast response electrical controlling;
- ◆ PLC monitor entire production process, 300 sets of production recipes can save and USB data transmission conveniently;
- ◆ Platens temperature tolerance within  $\pm 2^\circ$  , PID temperature calibration;
- ◆ Multi demolding devices can be selected;
- ◆ CE Certification machine is available;
- ◆ First in First out injection is available.

First In First Out Injection



Series Main Technical Parameters  
主要技术参数

参数Parameters 型号Model No.	HYZ-200A		HYZ-300A		HYZ-400A		HYZ-500A		HYZ-580A	
锁模力 (KN) Clamping Force (KN)	2000		3000		4000		5000		5800	
注射量 (cm <sup>3</sup> ) Injection Volume (cm <sup>3</sup> )	2000	2400	3000	4000	3000	4000	3000	5000	5000	6000
热板尺寸(宽×长) (mm) Heating platen Size W*L (mm)	550 × 550		600 × 700		700 × 700		700 × 700		700 × 700	
热板间距 (mm) Space Btwn Platens (mm)	570		750		570		750		750	
哥林柱内距 (mm) Dimension between Tiebar (mm)	650 × 360		710 × 510		860 × 490		770 × 550		930 × 560	
开模行程 (mm) Max. Clamping Stroke (mm)	500		600		500		700		700	
最小模厚 (mm) Min. Mold Thickness (mm)	80		160		80		60		60	
装机容量 Total Power (KW)	28		40		45		55		55	
机器尺寸 Machine Size (M)	3.2 × 2.1 × 3.9		3.5 × 2.5 × 4.6		4.2 × 2.5 × 4.5		4.2 × 2.5 × 4.6		4.2 × 2.5 × 4.7	
机器重量 Machine Weight (T)	8		11		12.5		15		23	

We reserve the right to change specification without notice 如有参数变更, 恕不另行通知。

E series Rubber Injection Molding Machine  
E 系列橡胶注射成型机



Machine Characteristics  
机器特点

- ◆ Four-column vertical structure ensures machine durability;
- ◆ Right located oil tank, electrical cabinet and control panel, more back space for mold movements;
- ◆ Multi phases injection pressure and speed adapts multi molds production;
- ◆ Sturdy design of clamping unit for high stability and parallelism;
- ◆ Siemens or fast response electrical controlling;
- ◆ PLC monitor entire production process, 300 sets of production recipes can save and USB data transmission conveniently;
- ◆ Platens temperature tolerance within  $\pm 2^\circ$ , PID temperature calibration; Germany imported insulation plates prevents heat loss efficiently;
- ◆ Multi demolding devices can be adopted;
- ◆ CE Certification machine is available;
- ◆ FIFO injection unit is available.

Series Main Technical Parameters  
主要技术参数

型号Model No.	HYZ-50E		HYZ-100E		HYZ-200E		HYZ-300E		HYZ-400E		HYZ-500E		HYZ-600E	
参数Parameters														
锁模力 (KN) Clamping Force (KN)	500		1000		2000		3000		4000		5000		6000	
注射量 (cm <sup>3</sup> ) Injection Volume (cm <sup>3</sup> )	300	500	500	1000	2000	2400	3000	4000	4000	5000	5000	8000		
热板尺寸(宽×长) (mm) Heating platen Size W*L (mm)	400×400		450×500		550×550		600×700	700×700	700×700	800×800	800×800		900×900	
热板间距 (mm) Space Btwn Platens (mm)	400		500		570		750		740		750		1000	
哥林柱内距 (mm) Dimension between Tiebar (mm)	540×290		610×335		650×360		820×560		860×490		770×550		1010×560	
开模行程 (mm) Max. Clamping Stroke (mm)	350		450		500		600		700		700		600	
最小模厚 (mm) Min. Mold Thickness (mm)	60		60		80		160		240		60		210	
装机容量 Total Power (KW)	22		25		28		40		55		55		57	
机器尺寸 Machine Size (M)	1.6×1.1×2.9		2.7×1.2×3.1		3.5×1.6×3.9		3.8×2×4.6		4.2×2.7×4.8		4.2×2.7×4.9		4.3×2.8×5	
机器重量 Machine Weight (T)	2.5		5.5		8		11		13		16		42	

We reserve the right to change specification without notice 如有参数变更, 恕不另行通知。

Rubber Injection Molding Machine With Solid Silicon Rubber Stuffer  
E型机配固态硅胶送料装置

Machine Characteristics  
机器特点

- ◆ With silicone stuffer, suitable for making cable accessories, low voltage insulators, arrestors, fuse cutout.



Rubber Tire Bladders Injection Molding Machine  
轮胎胶囊注射成型方案

Series Main Technical Parameters  
主要技术参数

型号Model No.	HYZ-200E	HYZ-400E	HYZ-600E	HYZ-800E	HYZ-1200E	HYZ-1500E
参数Parameters						
锁模力 (KN) Clamping Force (KN)	2000	4000	6000	8000	12000	15000
注射量 (cm <sup>3</sup> ) Injection Volume (cm <sup>3</sup> )	2400	6000	5000	10000	20000	20000
热板尺寸(宽×长) (mm) Heating Platen Size W*L (mm)	550×550	800×800	800×800	1000×1000	1400×1400	1400×1400
热板间距 (mm) Space Btwn Platens (mm)	750	1000	800	1400	1400	1700
开模行程 (mm) Max. Clamping Stroke (mm)	500	750	1200	1000	1000	1000
最小模厚 (mm) Min. Mold Thickness (mm)	260	260	410	410	410	710

We reserve the right to change specification without notice 如有参数变更, 恕不另行通知。



■ Turkey Project Service For Rubber Molding Project  
橡胶制品成型打包技术服务



Advantages for turnkey project service

- ◆ Make sure molds and machines mounting dimensions are matched well;
- ◆ Completely quality inspection for molds and machines before delivery;
- ◆ Before shipping, machine and molds are well prepared for future production;
- ◆ Professional technical support for customer to setup new rubber plant.

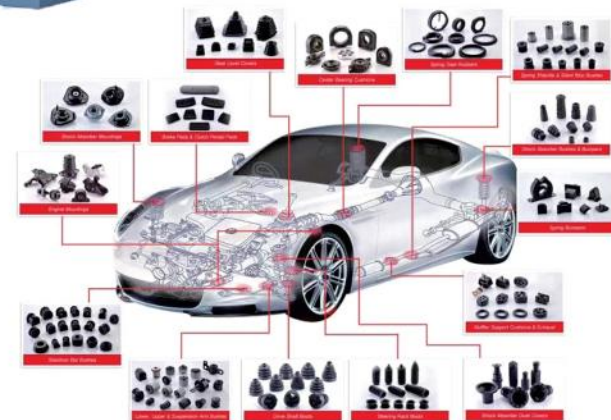

■ Rubber Injection Molding Machine for Insulators Compact Design  
绝缘子橡胶注射成型机（紧凑型）

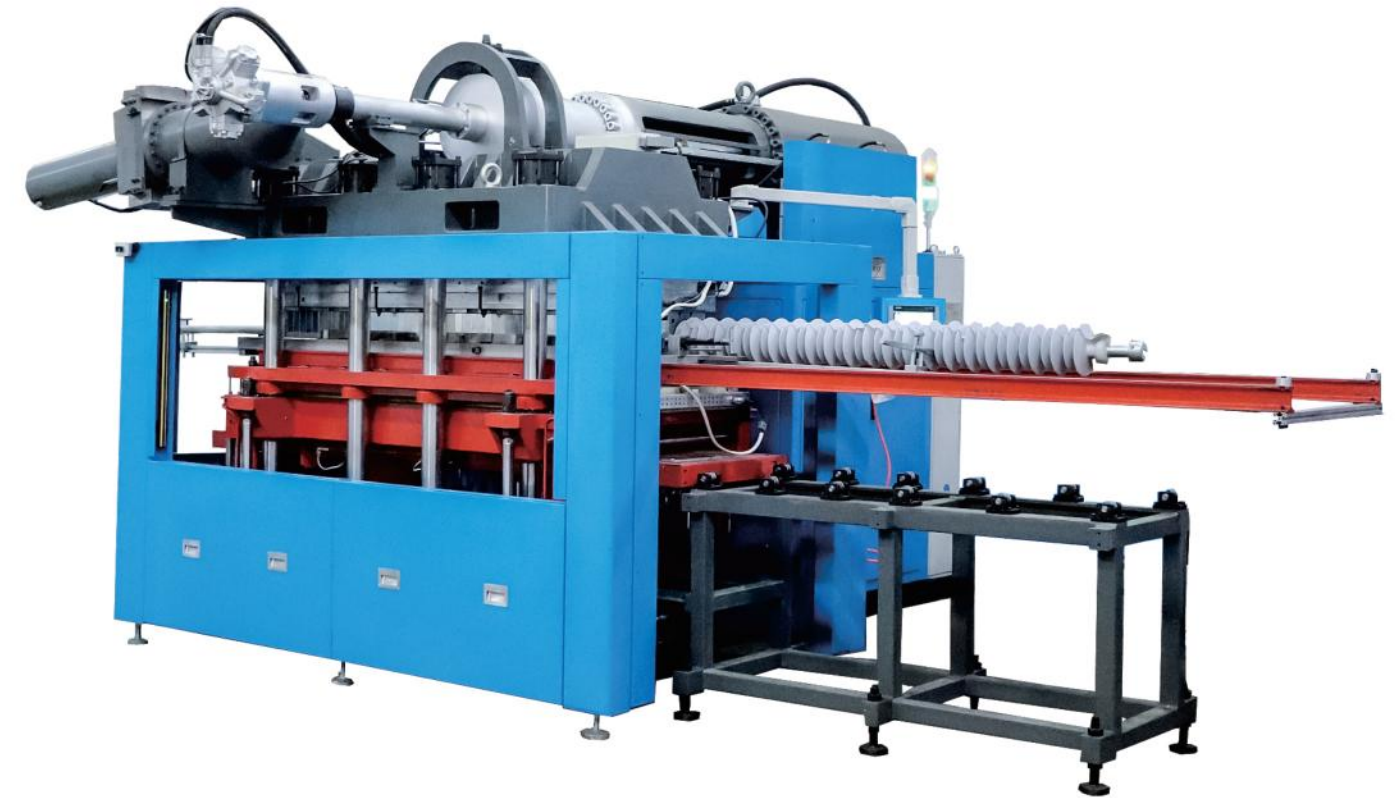

Series Main Technical Parameters

主要技术参数

参数Parameters	型号Model No.	HYZ-550B	HYZ-650B	HYZ-880B	HYZ-1000B	HYZ-1800B
锁模力 (KN) Clamping Force (KN)		5500	6500	8800	10000	18000
注射量 (cm <sup>3</sup> ) Injection Volume (cm <sup>3</sup> )		15000	20000	25000	40000	100000
热板尺寸 (宽×长) (mm) Heating platen Size W*L (mm)		630 × 2000	850 × 2300	900 × 2500	1000 × 2800	1000 × 2800
热板间距 (mm) Space Btwn Platens (mm)		780	650	750	1250	1250
哥林柱内距 (mm) Dimension between Tiebar (mm)		800 × 1340	1020 × 1530	1020 × 1530	As Per Design	As Per Design
开模行程 (mm) Max. Clamping Stroke (mm)		400	400	400	900	900
最小模厚 (mm) Min. Mold Thickness (mm)		390	350	350	350	350
锁模大缸个数 No. of Clamping Cylinders		2	2	2	2	2

We reserve the right to change specification without notice 如有参数变更, 恕不另行通知。

Machine Characteristics  
机器特点

- ◆ Double clamping cylinders and 8 columns for even clamping force distribution;
- ◆ Concise space saving design, low working height;
- ◆ New stuffer design better for material loading and air venting;
- ◆ Full Safty Protection Fence;
- ◆ Mold supporter guiding by tiebar specially design for insulators demoulding.

■ B Series Rubber Injection Molding Machine For Insulators  
B 系列橡胶注射成型机

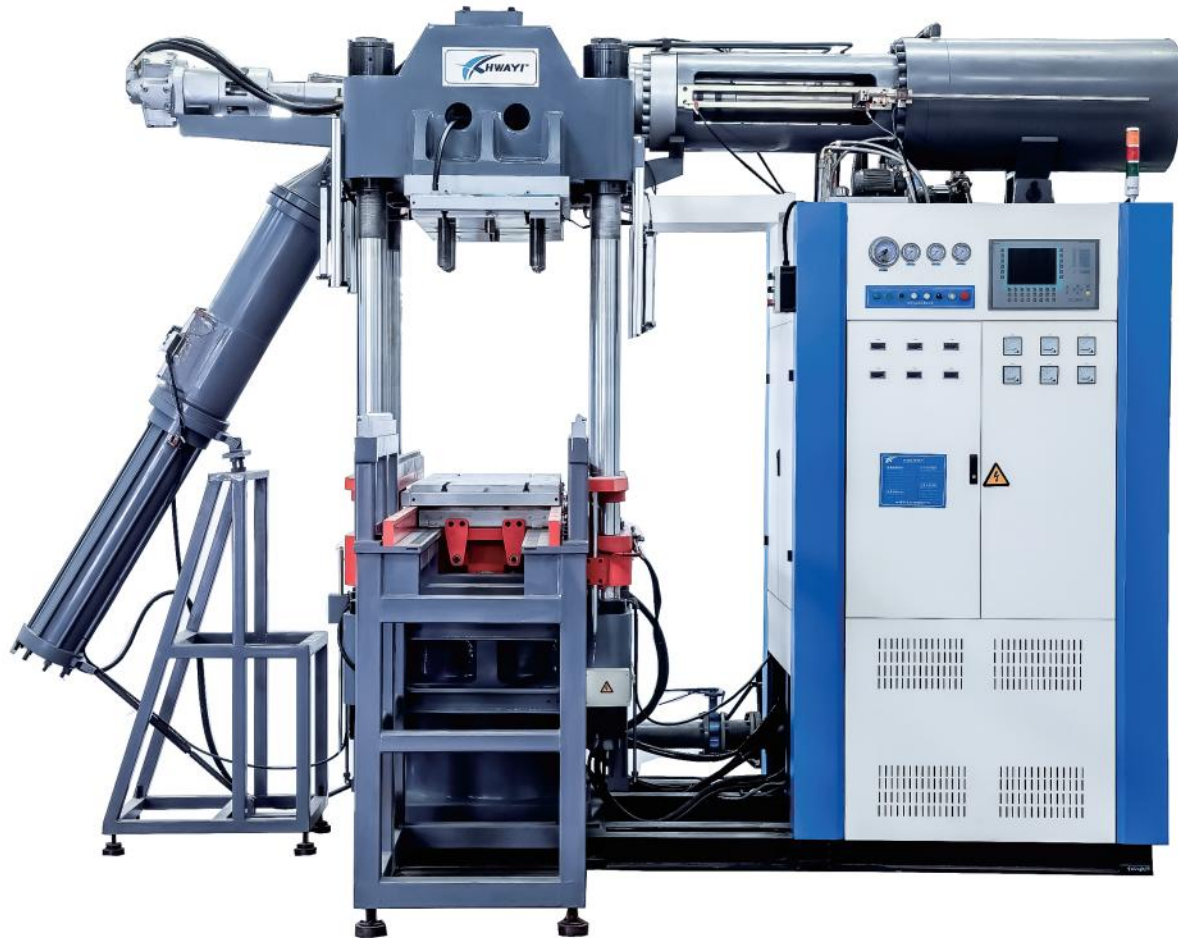

Machine Characteristics

机器特点

- ◆ Four-column with angle injection structure;
- ◆ Siemens PLC and international electrical components;
- ◆ Completely open stuffer, large injection volume, specially design for HTV rubber insulators, arrestors and hollow core bushings;
- ◆ Auto pre-heating system to promote work efficiency;
- ◆ Bigger clamping stroke, suitable for more sets of mould;
- ◆ Cold runner system, mold can be offered as options.



Series Main Technical Parameters  
主要技术参数

型号 Model No.	HYZ-200B	HYZ-300B	HYZ-500B	HYZ-650B	HYZ-800B	HYZ-1200B	HYZ-1800B	HYZ-2400B	
锁模力 (KN) Clamping Force (KN)	2000	3000	5000	6500	8000	12000	18000	24000	24000
注射量 (cm³) Injection Volume (cm³)	2000	4000	10000 15000	20000	28000 40000	30800 40000	40000 80000	80000	100000
热板尺寸 (宽×长) (mm) Heating platen Size W*L (mm)	550×550	600×1300	630×1500	650×1600	1000×1600	850×3500	1000×2800	850×5500	1200×3500
热板间距 (mm) Space Btwn Platens (mm)	570	780	940	1200	1600	850	1600	1000	1900
哥林柱内距 (mm) Dimension between Tiebar (mm)	650×360	680×500	780×580	920×710	1240×790	1200×2200	1240×2290	1200×4390	1540×2540
开模行程 (mm) Max. Clamping Stroke (mm)	500	600	700	700	1000	650	1200	650	1300
最小模厚 (mm) Min. Mold Thickness (mm)	80	190	250	510	610	210	410	360	610
装机容量 Total Power (KW)	28	45	80	80	110	150	175	175	160
机器尺寸 Machine Size (M)	3.8×1.8×2.8	5.1×2.7×2.9	5.1×2.5×3.5	5.3×3×3.8	7.2×3.5×5.3	7.1×5.5×3.8	8×2.7×5.1	9×5.5×4.5	9×7×6
机器重量 Machine Weight (T)	7	11.5	20	22	48	65	90	120	150

We reserve the right to change specification without notice 如有参数变更, 恕不另行通知。

HTV Insulators Molding Solution  
固态硅胶绝缘子成型解决方案

应用 Application	HTV Insulators Molding Solution											
机器型号 Machine Model	HYZ-200B		HYZ-300B			HYZ-500B/650B			HYZ-1200B		HYZ-2400B	
绝缘子型号 Insulators (KV)	11KV-25KV Insulators/Arrestors		11KV	25-35KV	66KV	66KV	132KV	220KV	400KV	220KV	330KV	400-500KV
成型次数 Molding Steps	1		1	1	1	1	1	2	3	1	1	1
模具腔数 Mold Cavities	2-4		16	6	2	2	2	2	2	2	2	2

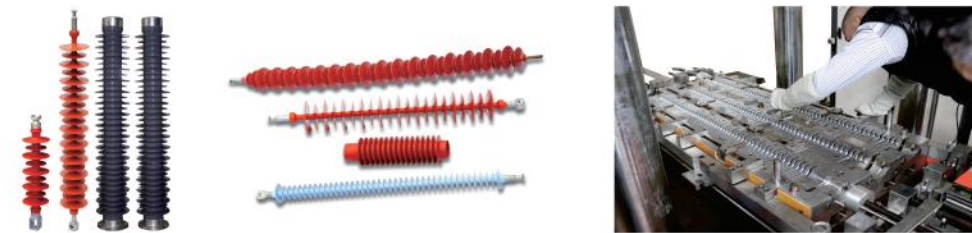

应用 Application	HTV Hollow Core Bushing Molding Solution			
机器型号 Machine Model	HYZ-650B	HYZ-800B	HYZ-1800B	HYZ-2400B
绝缘子型号 Insulators (KV)	110KV Hollow Core Insulators	220KV Hollow Core Insulators	220KV Hollow Core Insulators	400KV-500KV Hollow Core Insulators
成型次数 Molding Steps	1	2	1	1
模具腔数 Mold Cavities	1	1	1	1





- **Special Customized Rubber Machine(特殊定制机)**
- ▼ **300BFD Series FIFO Rubber Injection Molding Machine**  
300BFD系列先进先出橡胶注射成型机



- ▼ **300EV Series Rubber Vacuum Injection Molding Machine**  
300EV系列抽真空橡胶注射成型机



- **All Kinds Of Sealing Profiles Joints Molding Solution**  
各种密封条接角方案

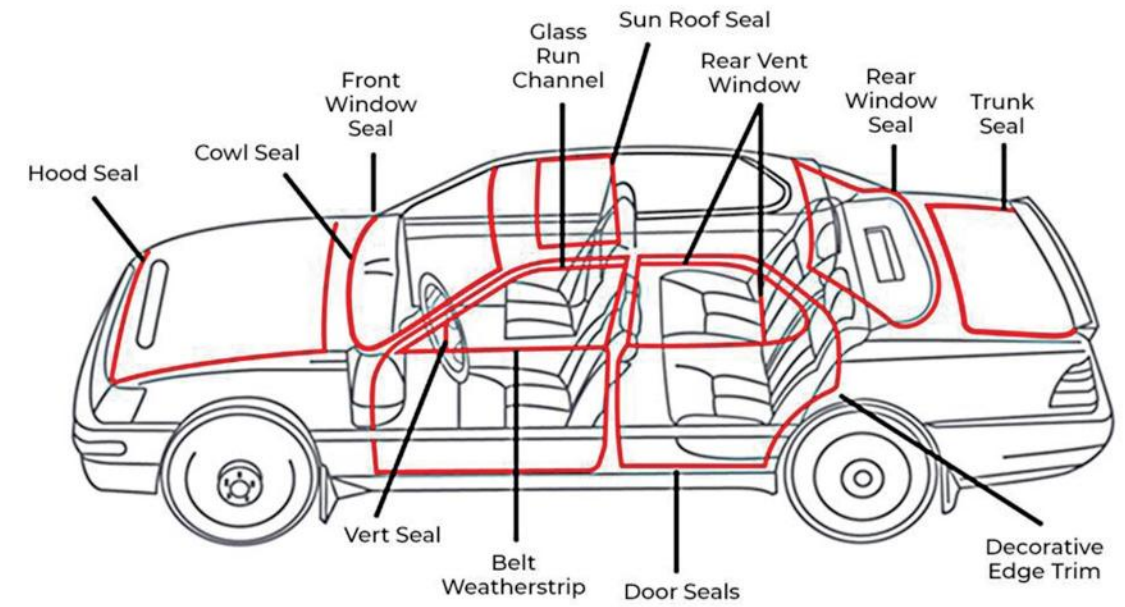

**Specialized in Molding TPE and EPDM Sealing Joints**

■ C Frame EPDM Injection Press  
EPDM密封条接角机



Machine Characteristics  
机器特点

- ▶ EPDM sealing strips junctions molding machine;
- ▶ C frame structure , complete open structure;
- ▶ No Injection runner, all in all out injection system, top injection or bottom injection is optional;
- ▶ No need check valve and metering, more accurate injection;
- ▶ Injection accuracy is  $\pm 0.5\%$ , CPK  $\geq 1.67$ ;
- ▶ Platens temperature tolerance within  $\pm 2^\circ$  , PID temperature calibration; germany imported insulation plates prevents heat loss efficiently;
- ▶ No broken rubber in the feeding area;
- ▶ Double working station is optional;
- ▶ Upper lifter, sliding, ejector , core pulling valves adopts for different mold requirements;
- ▶ CE certification machine is available.



Series Main Technical Parameters  
主要技术参数

型号Model No.	HYZ-15J		HYZ-30J		HYZ-50J		HYZ-80J		HYZ-100J		HYZ-150J		HYZ-200J		HYZ-250J	
锁模力 (KN) Clamping Force (KN)	150		300		500		800		1000		1500		2000		2500	
注射量 (cm <sup>3</sup> ) Injection Volume (cm <sup>3</sup> )	50	100	100	160	160	300	300	500	300	500	300	500	300	500	500	800
热板尺寸(宽×长) (mm) Heating platen Size W*L (mm)	300×300		350×400		450×400		750×500		600×500		750×500		600×500		750×650	
热板间距 (mm) Space Btwn Platens (mm)	350		350		400		640		640		640		780		1000	
开模行程 (mm) Max.Clamping Stroke (mm)	300		300		350		500		500		500		600		700	
最小模厚 (mm) Min.Mold Thickness (mm)	60		60		60		150		150		150		180		300	
装机容量 Total Power (KW)	20		20		21		28		28		28		28		60	
机器尺寸 (M) Machine Size (M)	1.6×1.4×2.9		1.8×1×2.7		2×1×3		2.5×1.5×3.5		2.5×1.5×3.8		2.5×1.5×4		2.5×1.5×4		4×3×4.5	
机器重量 Machine Weight (T)	1.5		2		3		6.5		8		9		9		16	

We reserve the right to change specification without notice 如有参数变更, 恕不另行通知。

■ C Frame TP Injection Press  
TP密封条接角机

Machine Characteristics  
机器特点

- ◆ TPV/TPE seal profiles joints injection machine;
- ◆ C Frame structure to widen operation space;
- ◆ First in first out to promote high injection temperature;
- ◆ SIEMENS(B&R) PLC high precision and fast response controlling system;
- ◆ High precision and stability, injection accuracy  $\pm 0.5\%$  (CMK  $\geq 1.67$ );
- ◆ High energy saving, servo driven system can save 30-70% of power;
- ◆ Injection and plasticizing precision controlled by rexroth servo valves;
- ◆ Platens parallelism within 0.06 mm;
- ◆ Ethernet interface to remote assistance;
- ◆ Mold and operator safety protection, hydraulic security, which conforms to CE standard;
- ◆ Air dryer and mold temperature controlling module, hot runner controlling module, air valves, core pulling valves are selectable.



Series Main Technical Parameters  
主要技术参数

型号Model No.	HYZ-40JT		HYZ-50JT		HYZ-80JT		HYZ-100JT		HYZ-160JT		HYZ-200JT		HYZ-250JT	
锁模力 (KN) Clamping Force (KN)	400		500		800		1000		1600		2000		2500	
注射量 (cm <sup>3</sup> ) Injection Volume (cm <sup>3</sup> )	115	160	160		210		200		600		600		600	
热板尺寸(宽×长) (mm) Heating platen Size W*L (mm)	600×400		650×400		750×500		750×500		750×650		800×700		800×700	
热板间距 (mm) Space Btwn Platens (mm)	710		750		645		800		850		1000		1000	
开模行程 (mm) Max.Clamping Stroke (mm)	460		500		500		650		500		500		500	
最小模厚 (mm) Min.Mold Thickness (mm)	260		250		150		150		350		500		500	
机器尺寸(L×W×H)(m) Machine Dimension	2×1.4×3.7		2.1×1.5×3.8		2.1×1.6×4		2.1×1.6×4		2.3×1.6×4.2		2.5×1.6×4.5		2.7×1.8×4.7	
工作台高度 Working Table Height (mm)	950±50		950±50		950±50		950±50		1000±50		1000±50		1000±50	
机器重量 Reference Weight (TON)	4.3		4.5		8.5		8.5		11		13		16	

We reserve the right to change specification without notice 如有参数变更, 恕不另行通知。



## F Series LSR Clamping Machine

F系列液态硅胶成型锁模机

### Machine Characteristics 机器特点

- ◆ Huayi special design, state patent owner;
- ◆ High safety, the clamping platens slides on the guiding rails on the machine base;
- ◆ Convenient operation, tiebar-less structure with upper space, convenient to load and install molds and FRP tubes by crane or forklift;
- ◆ Robust design of clamping unit and machine base with high stability and perfect parallelism;
- ◆ Adopt close loop control injection, can cooperate with multi sets of molds with different phases pressure and speed setting;
- ◆ LSR clamping machine, pump machine, metering machine with molds can be offered as turnkey project.

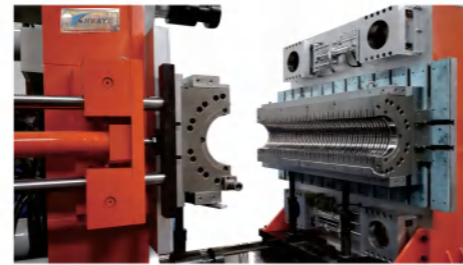

### Series Main Technical Parameters 主要技术参数

型号/Model No.	HYZ-100F	HYZ-200F	HYZ-300F	HYZ-400F
参数/Parameters				
锁模力 (KN) Clamping Force (KN)	1000	2000	3000	4000
热板尺寸 (mm)(宽×长) Platen Size(mm)(W×L)	700×1200	800×1600	1200×2400	1500×3000
热板间距 (mm) Space of Platens(mm)	1200	1600	1900	2700
立柱内距 (mm) Dimension Btwn Tie Bar(mm)	无拉杆 Without Tie Bar	无拉杆 Without Tie Bar	无拉杆 Without Tie Bar	无拉杆 Without Tie Bar
最大合模行程 (mm) Max.Clamping Stroke(mm)	800	1000	1400	2000
最小模厚 (mm) Min.Mold Thickness(mm)	400	610	500	710

We reserve the right to change specification without notice  
如有参数变更, 恕不另行通知。

## 800KV Hollow Core Bushings Needs 4 Molding Steps 1100KV Hollow Core Bushings Needs 7 Molding Steps



### LSR Dosing Machine 液态硅胶计量机



## Rubber Belt Track Vulcanizing Press

橡胶履带专用硫化机



### Machine Characteristics 机器特点

- ◆ High automation: automatically load rubber material; automatically tense steel belt; tracks taking off semi-automatically;
- ◆ Flexible installation: special telescopic design applied on fast clamping device to decrease operation height efficiently;
- ◆ Energy-saving: hydraulic pump adjusts the energy consumption during curing to avoid the energy lost, clamping force keep stable always;
- ◆ Hydraulic precisely control multiple actions: the flow of the pump can be precisely adjusted from 0 to 100% during the multiple actions;
- ◆ Longer product life: perfect performance between clamping unit and tensing device improve the belt track life 50% longer;
- ◆ Smart product quality control: smart control with B&R system, automatic data adjusting & saving function, monitor and track production data to analyze the production stability & improve product quality.

### Series Main Technical Parameters 主要技术参数

型号/Model	HYL-160P	HYL-280P	HYL-360P	HYL-480P	HYL-650P	HYL-900P
参数/Parameters						
锁模力 (KN) Clamping Force (KN)	1600	2800	3600	4800	6500	9000
上下热板尺寸 (mm)(LxW) Top/Bottom Heating Platen	950×600	1550×650	1700×800	1700×800	1960×1050	2250×1050
中热板尺寸 (mm)(LxW) Middle Heating Platen	950×600	1550×650	1500×800	1700×800	1960×1050	2050×1050
热板间距 Space of Platens(mm)	540	550	550	550	900	700
开模行程 Mold Close Stroke(mm)	450	400	400	400	720	550
最小模厚 (mm) Min.Mold Thickness(mm)	100	150	150	150	180	150
履带最大宽度 Max.Width of Track(mm)	400	450	550	550	800	457-914
硫化履带长度 Range of Track(mm)	2560-3520	3780-4860	4600-6200	4800-6400	5900-8500	5900-8500
系统压力 System Pressure(Mpa)	21	21	21	21	21	21

We reserve the right to change specification without notice  
如有参数变更, 恕不另行通知。

■ V Series Vacuum Vulcanizing Press  
V系列真空平板硫化机



Germany Vacuum Pump

Machine Characteristics  
机器特点

- ◆ Adopts four-column structure;
- ◆ Front auxiliary unit separated from the moving plate, suitable for multi de-moulding methods;
- ◆ Germany busch vacuum pump, excellent stable vacuumization.

Series Main Technical Parameters  
主要技术参数

型号/Model	HYL-100V (double station)	HYL-200V (double station)	HYL-300V (double station)	HYL-400V (double station)
参数Parameters				
锁模力 (KN) Clamping Force (KN)	1000	2000	3000	4000
热板尺寸 (mm)(宽×长) Platen Size(mm)(W×L)	450×450	550×550	650×650	700×700
热板间距 (mm) Space of Platens(mm)	350	350	350	350
立柱内距 (mm) Dimension Btwn Tiebar(mm)	610×225	690×290	790×340	860×490
最大合模行程 (mm) Max.Clamping Stroke(mm)	300	300	300	300
最小模厚 (mm) Min.Mold Thickness(mm)	60	60	60	60
移模行程 Sliding Stroke(mm)	540	600	650	750
顶出行程 Ejection Stroke(mm)	260	260	260	260
抽真空速率 Vacuum pumping rate (m³/h)	100	100	100	100
真空室内部尺寸 Vacuum Chamber Inner Size (mm)	520×530	610×580	723×672	730×830
装机容量 Total Power (KW)	38	40	51	55
机器尺寸 Machine Size (M)	32×21×23	36×23×25	36×25×26	4×28×28
机器重量 Machine Weight (T)	8.5	12	15	22

We reserve the right to change specification without notice 如有参数变更, 恕不另行通知。

■ P Series Vulcanizing Press  
P系列平板硫化机

Machine Characteristics  
机器特点

Adopt four-column structure with the split structure design between the front auxiliary unit and moving plate. It is suitable for many kinds of de-moulding methods and mould usage. This type machine is suitable for large rubber products making, such as railway shock absorption parts etc.

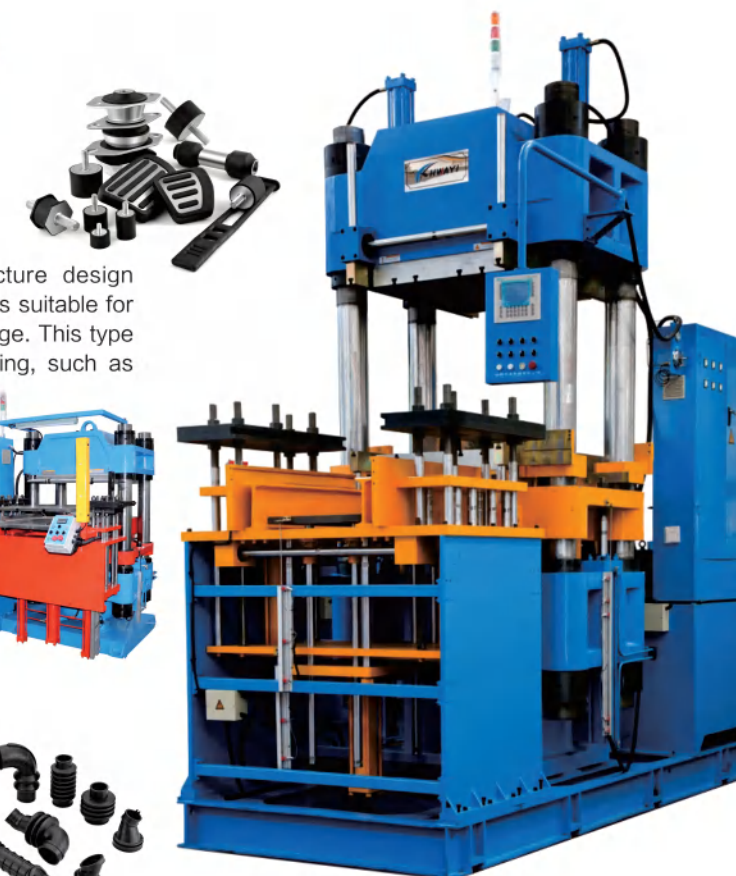
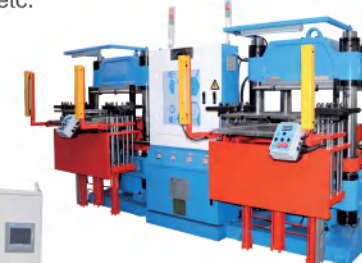

Series Main Technical Parameters  
主要技术参数

型号/Model	HYL-100P (double station)	HYL-200P (double station)	HYL-300P (double station)	HYL-400P (double station)	HYL-600P	HYL-800P	HYL-1000P	HYL-1200P	HYL-2000P
参数Parameters									
锁模力 (KN) Clamping Force (KN)	1000	2000	3000	4000	6000	8000	10000	12000	20000
热板尺寸 (mm)(宽×长) Platen Size(mm)(W×L)	450×450	550×550	650×650	800×800	900×1100	1000×1200	1200×1400	1500×2000	2000×2000
热板间距 (mm) Space of Platens(mm)	350	350	350	350	900-1300	850	1100	1100-1400	900-1300
立柱内距 (mm) Dimension Btwn Tiebar(mm)	610×225	690×290	790×340	860×490	1110×710	1300×700	1300×700	1800×1000	2440×1240
最大合模行程 (mm) Max.Clamping Stroke(mm)	300	300	300	300	800	700	900	1100	900
最小模厚 (mm) Min.Mold Thickness(mm)	60	60	60	60	110-510	150	210	0-310	0-410
移模行程 Sliding Stroke(mm)	540	600	650	750	600	1300	1400	2010	/
顶出行程 Ejection Stroke(mm)	260	260	260	260	450	450	450	450	/
装机容量 Total Power (KW)	38	40	51	55	60	85	85	38 (steam heating)	45 (steam heating)
机器尺寸 Machine Size (M)	32×21×23	36×23×25	36×25×26	4×28×28	35×3×4	45×22×35	46×21×47	63×24×47	63×32×52
机器重量 Machine Weight (T)	7.5	10	13	18	18	30	40	60	120

We reserve the right to change specification without notice 如有参数变更, 恕不另行通知。



■ Full Automatic Rubber Tracks Preforming Press Molding Line  
全自动橡胶履带预成型生产线

Machine Characteristics  
机器特点

- ◆ 设计目的: 自动输送铁齿, 铁齿精确定位, 自动称重, 自动裁断预成型生产线包含以下装置;
- ◆ 铁齿输送, 中胶存放与牵引, 底胶存放与牵引, 预成型压机, 成品拖动, 成品裁断, 成品转运。
- ◆ Design purpose: automatic counting& putting iron links, iron links accurate positioning, automatic weighing, automatic cutting;
- ◆ The preforming line consists of the following devices: Iron links transportation, middle rubber storage & traction, Bottom rubber storage & traction, preforming press, finished product drag, finished product cutting, finished product transferring.



Auto Gaskets Molding Press  
700ton Clamp Force  
Platen Size 900\*1500mm

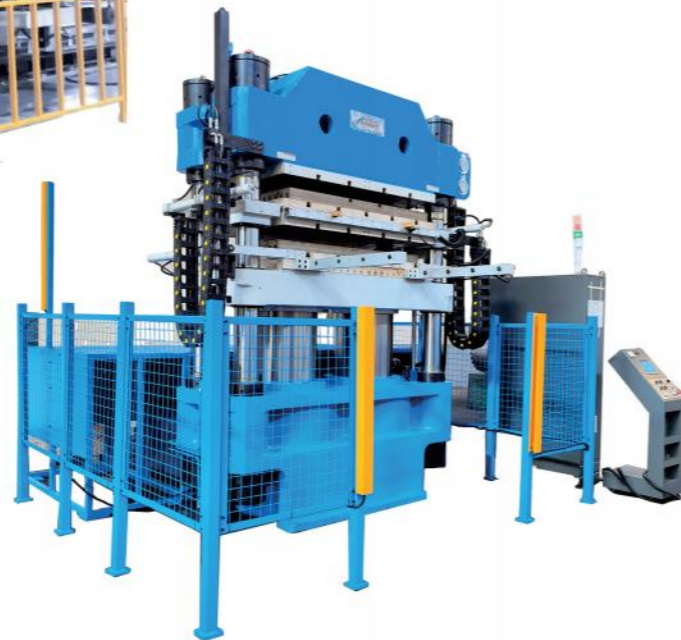

Building Dampers Press  
3000ton Clamp Force  
Platen size 2000\*3000mm

De-Molding Mechanism  
脱模装置

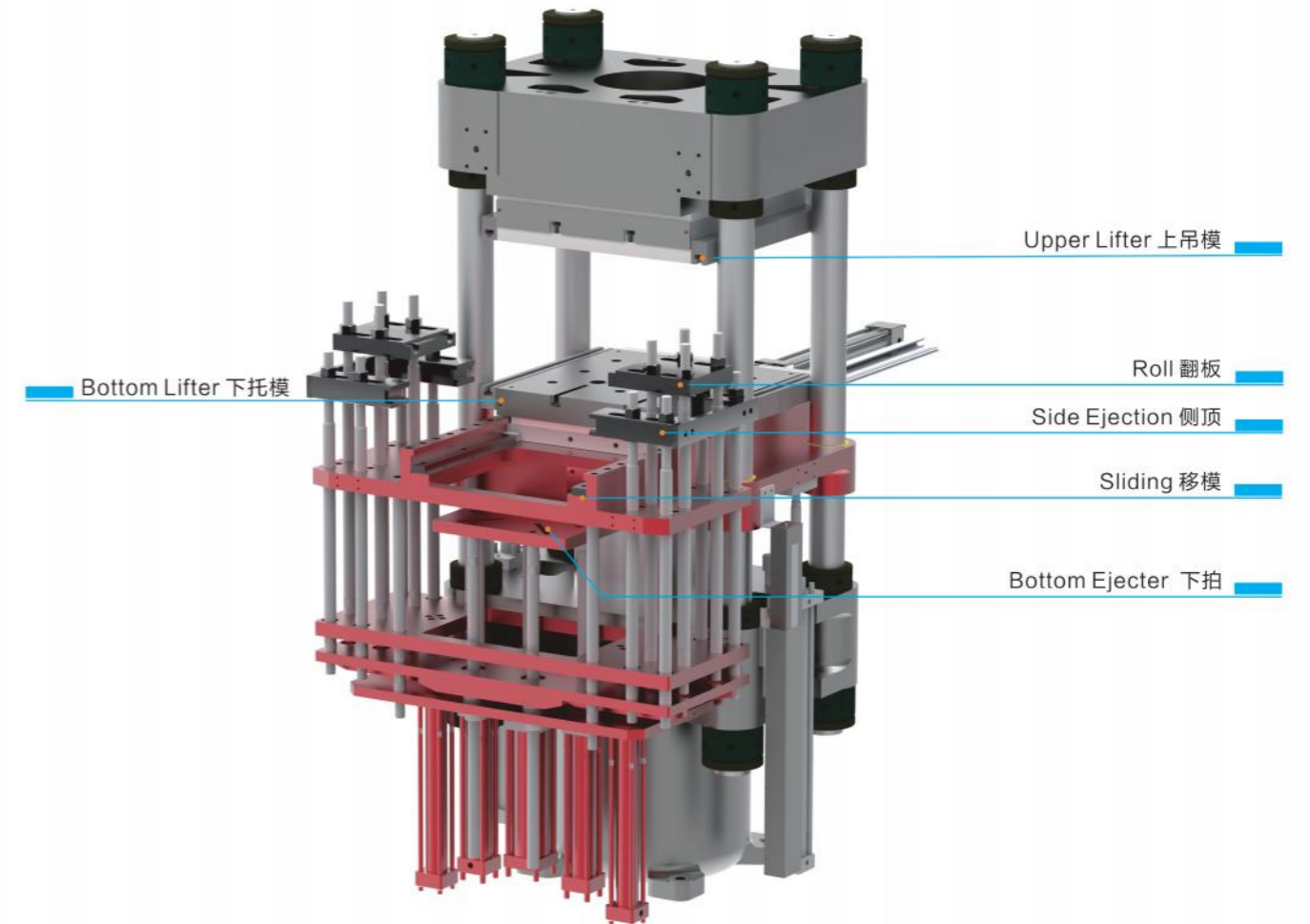
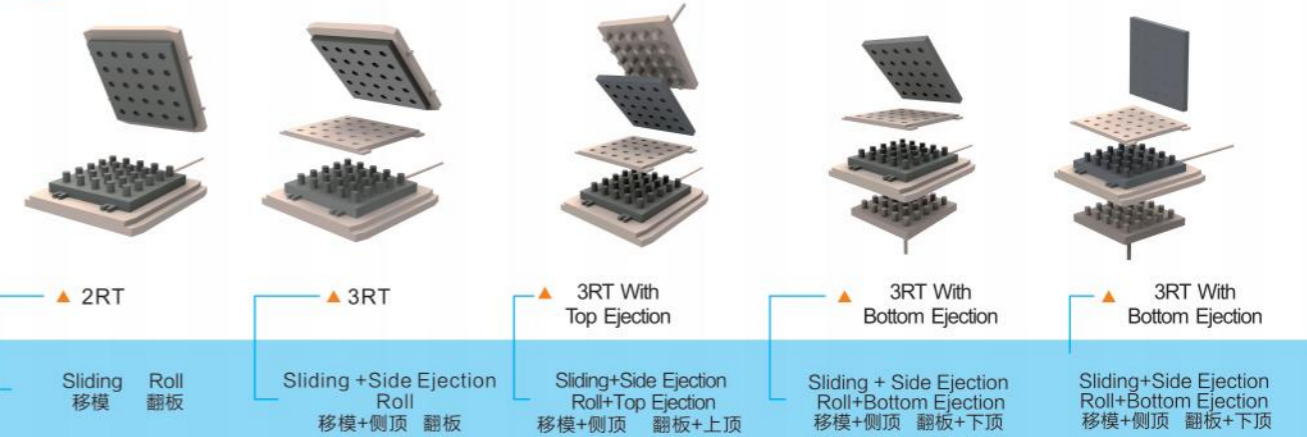



## Customer sites

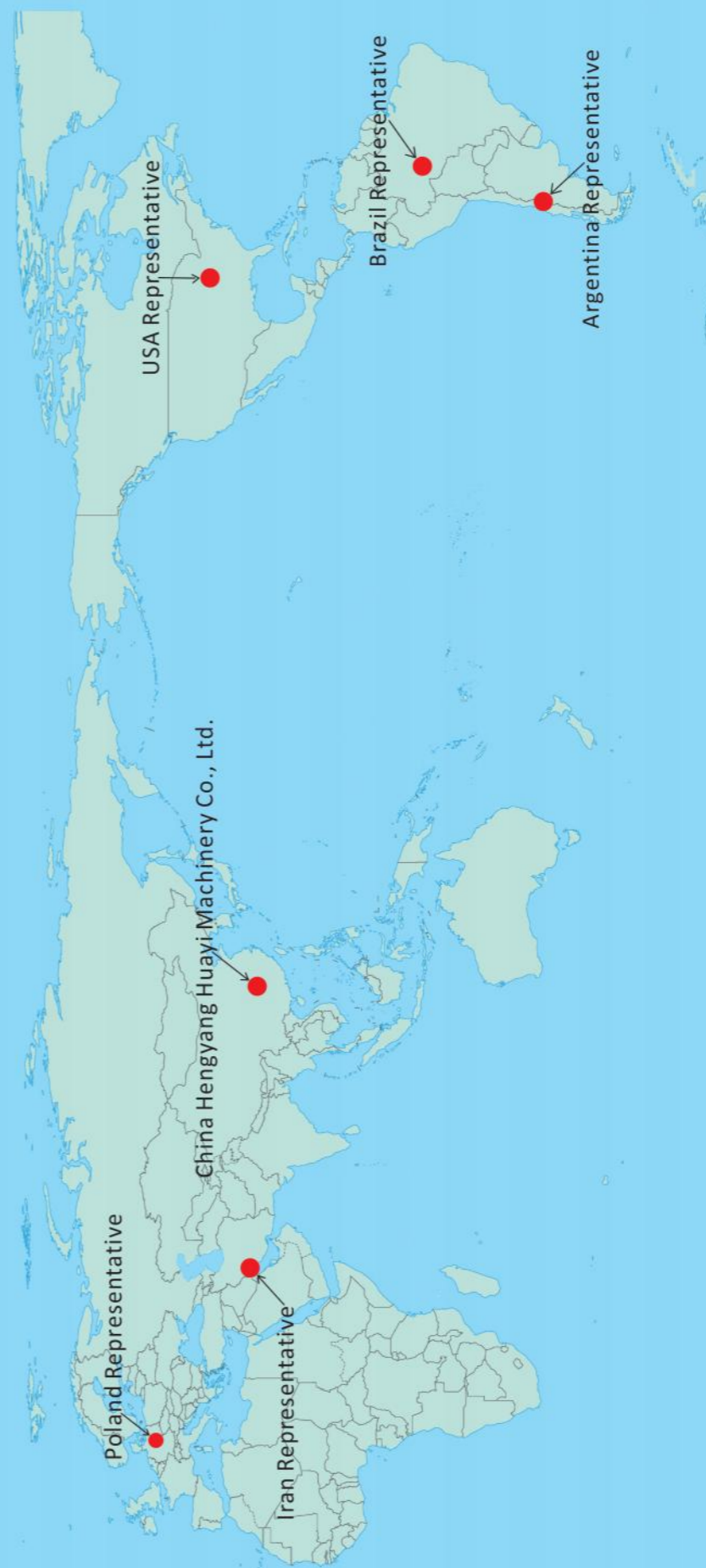

Welcom your attention to be our partner

Head office & plant:  
Hengyang Huayi Machinery Co., Ltd.  
No.1 Xiangshan Hamlet, Miaopu Street,  
Zhuhui  
District, Hengyang, Hunan, China.  
TEL: 0086 734 8323019  
Email: huayijx@huayijx.com