



设备畅销全球55个国家和地区

Machines are popular in more than 55 countries and regions.



微信视频号



抖音号

南通恒康数控机械股份有限公司

地址: 江苏省如皋市丁堰镇陈草路89号
电话: +86-513-88532596 传真: +86-513-88532599
邮箱: cnchkpcb@163.com janet@hkfoam.cn doris@hkfoam.cn

Nantong Healthcare Machinery Co., Ltd

ADD: Dingyan, Rugao, Jiangsu Prov., China 226521
TEL: +86-513-88532596 FAX: +86-513-88532599
E-mail: CNCHKPCB@163.COM JANET@HKFOAM.CN DORIS@HKFOAM.CN

数控海绵切割机
自动化切割流水线
床垫智能生产线
储运系统
订单管理系统
整厂规划设计

CNC Foam Cutting Machine
Automatic Cutting Line
Mattress Production Line
Storage and Transportation System
Order Management System
Your Custom Plant



专注软体行业 20 年
Focus on foam industry for 20 years

省级高新技术企业 Provincial high-tech enterprises	专精特新中小企业 Specialized、Refined、Differentiated、Innovative	质量体系认证 Quality System certification
始于2003年 Since 2003	为软体行业提供一站式生产解决方案 One-stop solution for foam industry	

企业使命 MISSION	- 为软体行业提供更高效率、更精准的异型切割设备; - 让更多的企业获得更智能的流转方案。 - To provide high-efficient and high-precision CNC contour cutting machines for the foam industry; - Provide the smart transportation systems.
企业愿景 VISION	- 让恒康数控成为世界一流的设备制造商 - To become a world-class machine manufacturer
核心价值观 VALUE	客户至上 信守承诺 高效创新 爱岗敬业 Customer-centricity; Trust-worthiness; Commitment; Efficiency; Innovation



我们的优势
Our advantage

自主研发和生产
Independent Research and Development

- 授权专利**70**多件
More than 70 patents were granted
- 工厂占地**27000** m², 全流程生产线
Our well-equipped factory spanning an area of 27000 m²

源自中国, 服务全球
From China, serving the world

- 服务团队**20**多人
Service team of more than 20 people
- 销往**50**多个国家和地区
More than 50 countries and regions
- **4000**多台设备在世界各地使用
More than 4,000 machines are running world widely

服务理念, 为客户创造价值
The best pre-and after sales service

- 完善的零备件供应链
- 积极响应客户需求, 同时提供电话、邮件、视频、邮寄及现场服务
- 现场服务: 国内服务2个工作日抵达现场, 境外服务10天内抵达现场
- 自主研发的绘图及操作软件, 新手小白2天内包学包会
- 切割软件终身免费升级维护
- 硬件一年免费服务
- Machines are delivered with the most important wear and spare parts;
- Our motors and components are of world famous brands, readily world-wide available and easy to exchange in the unlikely case of failure;
- Telephone, e-mail and local service are available;
- Free software maintenance and updates for life;
- One year warrantee, extended warrantee also available;
- All components are available in our stock.



软体行业 - 一站式整厂解决方案

Provide One-stop Solutions for Foam Industry- Intelligent Digital Visualization

海绵立体存储线
Intelligent Rack System

移载升降车
Lifting Table

自动切割流水线
Automatic Cutting Line

短泡仓库
Short Block Storage System

床垫智能生产线
Mattress Production Line



单横刀 CNCHK-2



样品展示 Sample



技术参数表 Technical Date

块料最大尺寸	Max.Block size	3000*2100*1300mm
机器总功率	Power	5KW, 380V, 50HZ
刀具尺寸	Blade size	2400*3*0.6mm,tooth-type
切割速度	Speed	Max.20m/min
切割精度	Accuracy	±0.5mm
设备外观尺寸	Equipment size	6100*3250*2250mm
选配	Option	压辊, Press roller

适用领域: 海绵行业、家具软体行业、包装行业、汽车行业、化妆品行业、日用品行业、建筑行业
Industries: Foam, Furniture, Mattresses, Packaging, Automobile, Household, Building, etc.

单竖刀 CNCHK-3



样品展示 Sample



技术参数表 Technical Date

块料最大尺寸	Max.Block size	3000*2200*1300mm
机器总功率	Power	5KW, 380V, 50HZ
刀具尺寸	Blade size	1630*3*0.6mm,tooth-type
切割速度	Speed	Max.20m/min
切割精度	Accuracy	±0.5mm
设备外观尺寸	Equipment size	6200*3300*2500mm
压辊	Press roller	已安装 Installed

性能特点 Advantage:

- 精度高 High precise cutting.
- 可断点加工 Can continue the cutting after break.
- 自主研发高精度电子跟踪系统, 实现完全同步 (防断刀)
High-precision monitoring system ensure the fully synchronization of motors, to avoid blade broken.
- 伺服保护系统 Servo protection system installed.
- 无粉尘 Dust-free.
- 刀片耐用 Blade with a long service life.
- 振动箱稳定耐用, 终身维护 Stable & durable gearbox. Lifetime maintenance.
- 自动排版, 一键生成最优切割路径 Auto nesting and optimal cutting path generation.

可切材料: 海绵、乳胶、再生绵、密胺海绵、过滤棉

Material: PU flexible foam, HR, Memory foam, Latex, Rebond foam, Melamine foam, filter type foam, etc.



旋转台 CNCHK-4



适用领域: 海绵行业、家具软体行业、包装行业、汽车行业、化妆品行业、日用品行业、建筑行业
Industries: Foam, Furniture, Mattresses, Packaging, Automobile, Household, Building, etc.

可切材料: 海绵、乳胶、再生棉、密胺海绵
Material: PU flexible foam, HR, Memory foam, Latex, Rebond foam, Melamine foam, etc.

样品展示 Sample



技术参数表 Technical Date

块料最大尺寸	Max.Block size	2200*2200*1300mm
机器总功率	Power	5-6KW, 380V, 50HZ
刀具尺寸	Blade size	2400*3*0.6mm, tooth-type
切割速度	Speed	Max.20m/min
切割精度	Accuracy	±0.5mm
设备外观尺寸	Equipment size	5200*3200*2250mm, 手动旋转台 Manual Turntable 5800*3250*2350mm, 自动旋转台 Motorized Turntable
选配	Option	压辊 Press roller

安装尺寸图 Drawing

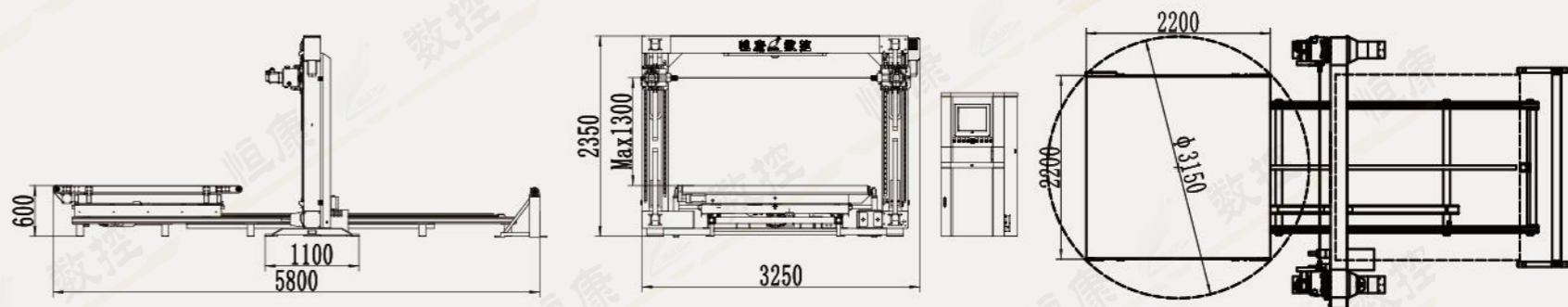

性能特点 Advantage:

- 精度高 High precise cutting.
- 可断点加工 Can continue the cutting after break.
- 自主研发高精度电子跟踪系统，实现完全同步（防断刀）
High-precision monitoring system ensure the fully synchronization of motors, to avoid blade broken.
- 伺服保护系统 Servo protection system installed.
- 无粉尘 Dust-free.
- 刀片耐用 Blade with a long service life.
- 振动箱稳定耐用，终身维护 Stable & durable gearbox. Lifetime maintenance.
- 自动排版，一键生成最优切割路径 Auto nesting and optimal cutting path generation.



双刀机 CNCHK-5



适用领域: 海绵行业、家具软体行业、包装行业、汽车行业、化妆品行业、日用品行业、建筑行业
Industries: Foam, Furniture, Mattresses, Packaging, Automobile, Household, Building, etc.

可切材料: 海绵、乳胶、再生棉、密胺海绵

Material: PU flexible foam, HR, Memory foam, Latex, Rebond foam, Melamine foam, etc.

样品展示 Sample

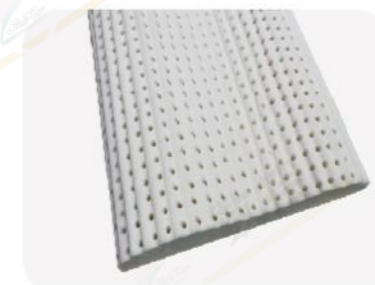

技术参数表 Technical Date

块料最大尺寸	Max.Block size	3000*2200*1300mm
机器总功率	Power	8KW,380V,50HZ
刀具尺寸	Blade size	2500*3*0.6mm, 1630*3*0.6mm, tooth-type
切割速度	Speed	Max.20m/min
切割精度	Accuracy	±0.5mm
设备外观尺寸	Equipment size	6700*3500*2500mm
压辊	Press roller	已安装 Installed

安装尺寸图 Drawing

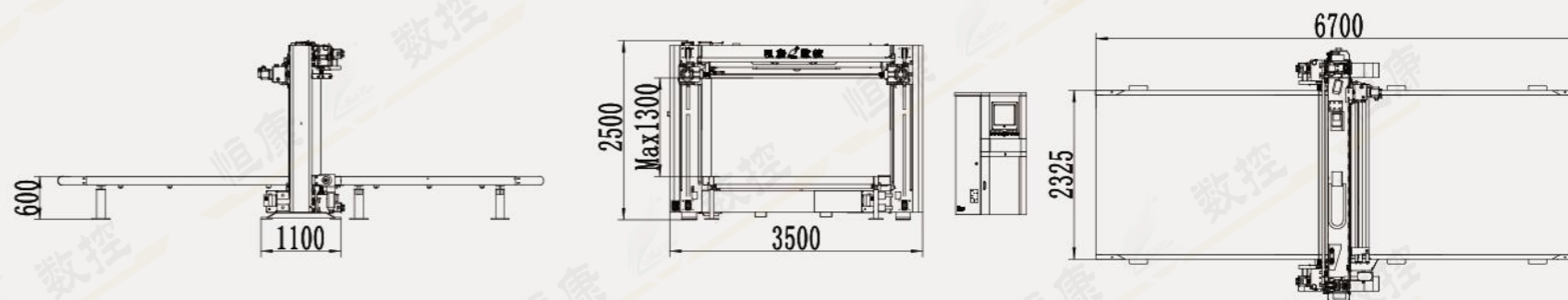

性能特点 Advantage:

- 精度高 High precise cutting.
- 可断点加工 Can continue the cutting after break.
- 自主研发高精度电子跟踪系统，实现完全同步（防断刀）
High-precision monitoring system ensure the fully synchronization of motors, to avoid blade broken.
- 伺服保护系统 Servo protection system installed.
- 无粉尘 Dust-free.
- 刀片耐用 Blade with a long service life.
- 振动箱稳定耐用，终身维护 Stable & durable gearbox. Lifetime maintenance.
- 自动排版，一键生成最优切割路径 Auto nesting and optimal cutting path generation.



环竖刀 CNCHK-9.1



适用领域: 海绵行业、家具软体行业、包装行业、汽车行业、化妆品行业、日用品行业、吸波隔音行业
Industries: Foam, Furniture, Packaging, Automobile, Household, Acoustics, etc.

可切材料: 海绵、PE、喷胶棉、海绵复合材料、密胺海绵、再生海绵、直立棉

Material: PU flexible foam, Rebond foam, PE, PP fiber, Coated materials (such as foam with fabric), Melamine foam, Visco

样品展示 Sample



技术参数表 Technical Date

块料最大尺寸	Max.Block size	3000*2200mm
可切块料高度	Max.Block height	1000mm,1200mm
机器总功率	Power	13KW,380V,50HZ
刀具尺寸	Blade size	14770*3.5*0.6mm,15150*3.5*0.6mm,
切割速度	Speed	Max.60m/min
切割精度	Accuracy	±1mm
扭刀范围	Torsion range of blade	±360°
磨刀系统	Grinding device	已安装 Installed
设备外观尺寸	Equipment size	6200*4710*3200(3300)mm
选配	Option	压辊 Press roller 升降台 Lifting table 挡板 Baffle

安装尺寸图 Drawing

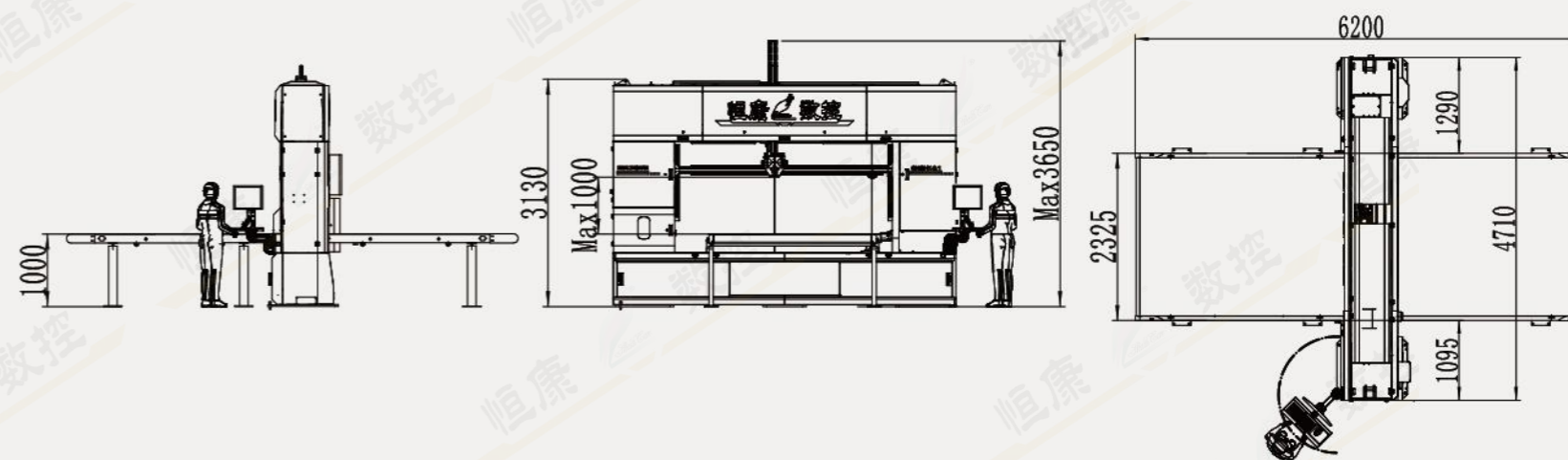

性能特点 Advantage:

- 无粉尘 Dust-free.
- 易损件少 Few wear parts.
- 切割速度快 Fast cutting speed.
- 操作简单, 自动进料、自动测量海绵尺寸、自动归零
Easy to operate. Automatic feeding, automatic detecting foam block and finding start point.
- 可断点加工 Can continue the cutting after break.
- 自动对刀 Automatic calibration of the knife angle.
- 自动化程度高, 节省人工 Reduce manpower.
- 适配性高, 可组流水线 Can be upgraded to an automatic cutting line.



自动分层切片机 CNCHK-9.4



适用领域: 海绵行业、家具软体行业、包装行业、汽车行业

Industries: Foam, Furniture, Packaging, Automobile, etc.

可切材料: 海绵、再生海绵

Material: PU flexible foam, Melamine foam

技术参数表 Technical Date

块料最大尺寸	Max.Block size	3000*2200*1250mm
机器总功率	Power	8KW,380V,50HZ
刀具尺寸	Blade size	10950*9.5*0.5mm,blade with double edge
切割速度	Speed	Max.100m/min
切割精度	Accuracy	±1mm
最小切割厚度	Minimal thickness	10mm
设备外观尺寸	Equipment size	5250×4300×3650mm
压板	Press Plate	已安装 Installed
选配	Option	吸盘装置 Vacuum device 全自动磨刀装置 Grinding device

样品展示 Sample

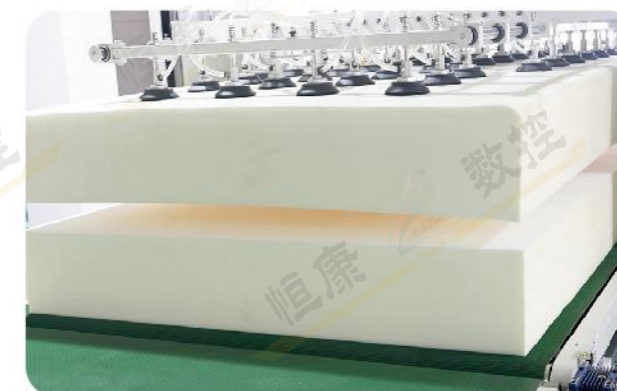

安装尺寸图 Drawing

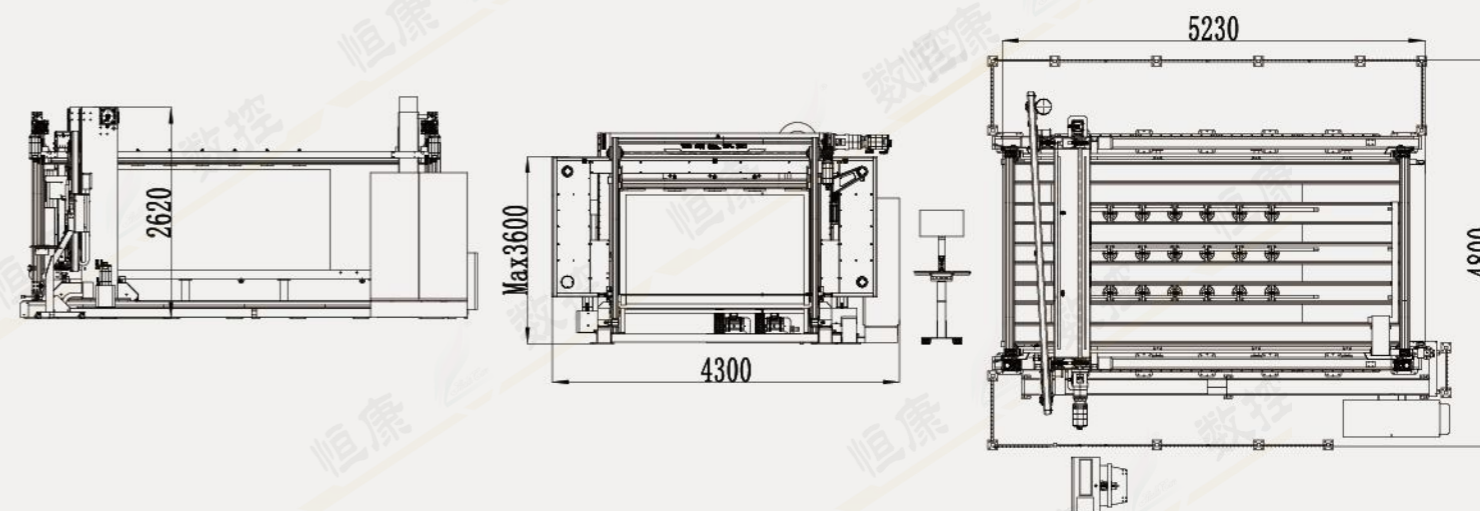

性能特点 Advantage:

- 易损件少 Few wearing parts.
- 切割速度快、海绵不错位 Fast cutting speed.
- 自动化程度高，操作简便 Fully automatic, easy to operate.
- 自动进料、自动测量海绵尺寸、自动归零 automatic feeding, automatic detecting foam block and finding start point.
- 无需图纸，设置层厚、数量即可进行切割（可分层切割多规格尺寸）
Set the desired thickness (different thickness) and quantity, no need make drawing.
- 采用双刃齿刀，可以来回切割、上下循环切割 Adopt double edged tooth blade to cut back and forward.
- 绝对值系统，稳定可靠，可组流水线
Absolute value of system, stable and reliable, can be upgraded to an automatic cutting line.



沙发行业 — 海绵切割成套产品线

Sofa Industry - Foam Cutting line for Complete Set of Products

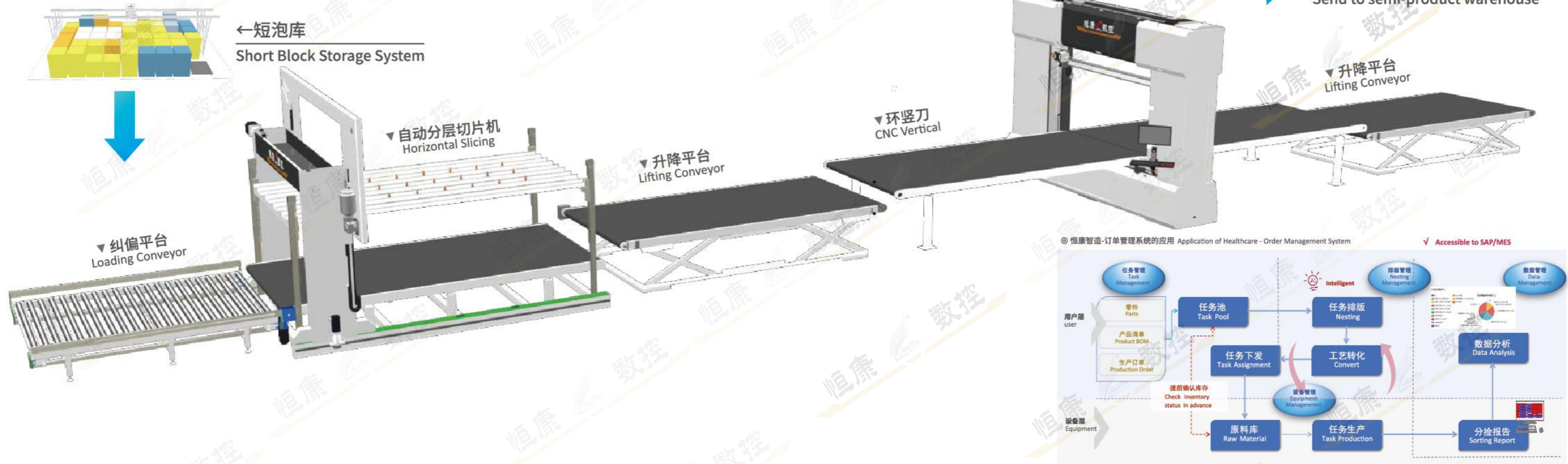

西门子控制系统 Siemens control system

稳定、兼容
Stable
compatible

多模式人机交互 Multi-mode Human-computer Interaction

单机/ 联动模式
Stand alone
Linkage mode

对接订单管理系统 Docking OMS

接入WMS
Access WMS

自动化程度高

- 无人化操作, 自动寻边/切割/进料/出料
- 切片与成型一次性完成
- 操作简单化: 降低人工技能要求

机器自动协同

- 一机双控, 多机联控
- 无需人工单独操作机器

任务预置

- 实现提前原材料备库
- 提升设备稼动率
- 避免人工出错

High Degree of Automation

- Unmanned operation- Automatic edge finding/ Feeding/ Cutting/ Output
- Slicing & Contour Cutting in one go

Automatic Machine Coordination

- One machine Dual Control; Multi-machine Joint Control
- No need operate the machines separately

Task Pre-set

- Realize raw material preparation in advance
- Improve Utilization
- Avoid human error

智能系统集成

- 搭配智能排单系统: 齐套率高
- 效率高: 100~120版/班次

操作模块化

- 工序流程化
- 操作简单化: 降低人工技能要求

数据可视化

- 数据溯源, 多维度报表生成
- 可视化分拣: 同步推送分拣报告, 下发分拣人员

Intelligent System Integration

- With Order Management System: High Rate of Complete Set
- Efficient: 100~120 drawing/shift

Operation Modularity

- Process flow streamlined
- Simplified operation: Reduce the operation skill requirements

Data Visualization

- Data traceability
- Multi-dimensional report generation
- Visual Sorting: Push sorting report synchronously, and send to sorting personnel



环横刀 CNCHK-9.2



适用领域: 海绵行业、家具软体行业、包装行业、汽车行业
Industries: Foam, Furniture, Packaging, Automobile, etc.

可切材料: 海绵、直立绵、再生海绵
Material: PU flexible foam, Visco, Melamine foam

样品展示 Sample

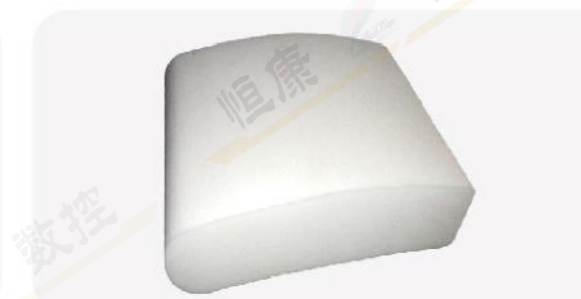
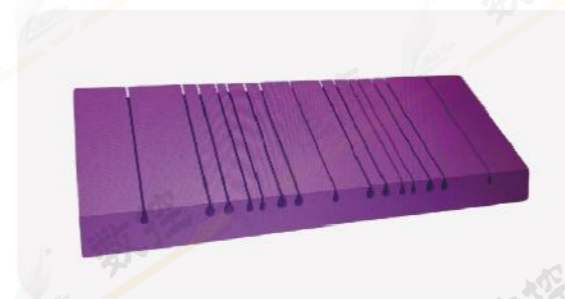

技术参数表 Technical Date

模式	Model	龙门移动式body move/平台移动式table move	
平台	Working Table	Conveyor Table	Turntable
块料最大尺寸	Max.Block size	3000*2200mm	2200*2200mm
可切块料高度	Max.Block Height	1300mm	1300mm
机器总功率	Power	10KW, 380V, 50HZ	10KW, 380V, 50HZ
刀具尺寸	Blade size	12470*3.5*0.6mm	12470*3.5*0.6mm
切割速度	Speed	Max.40m/min	Max.40m/min
切割精度	Accuracy	±1mm	±1mm
扭刀范围	Torsion range of blade	±360°	±360°
压辊	Press roller/plate	已安装 Installed	已安装 Installed
设备外观尺寸	Equipment size	7800*5400*3650mm	6000*4830*3650mm
选配	Option	全自动磨刀装置 Grinding device	

安装尺寸图 Drawing

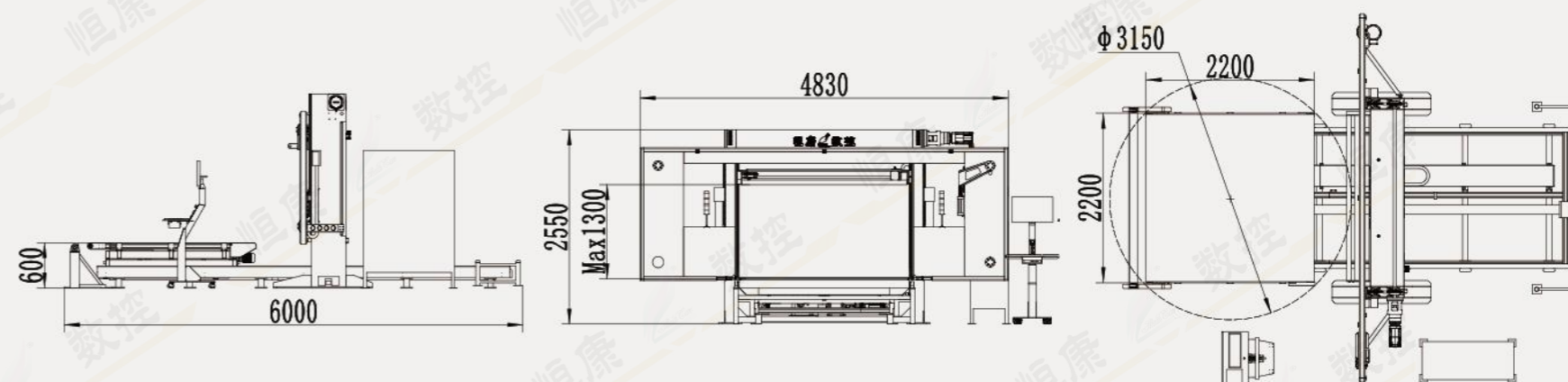

性能特点 Advantage:

- 无粉尘 Dust-free.
- 易损件少 Few wear parts.
- 切割速度快 Fast cutting speed.
- 操作简单, 自动进料、自动测量海绵尺寸、自动归零
Easy to operate. Automatic feeding, automatic detecting foam block and finding start point.
- 可断点加工 Can continue the cutting after break.
- 自动对刀 Automatic calibration of the knife angle.
- 自动化程度高, 节省人工 Reduce manpower.
- 适配性高, 可组流水线 Can be upgraded to an automatic cutting line.



智能滚胶机 CNCHK-10



样品展示 Sample

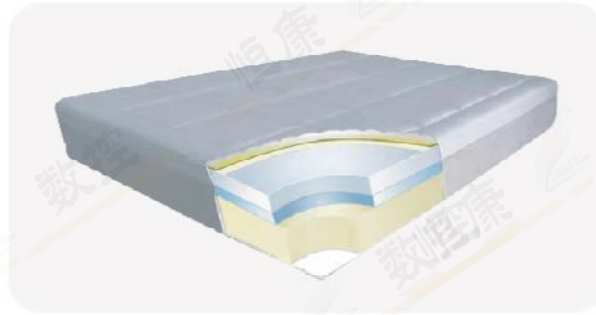

性能特点 Advantage:

- 省胶水 ($\approx 50g/m^2$), 省人工, 产能高, 可自动感应海绵高度, 自动加胶水功能, 可选手动或自动功能。
Automatic gluing, reduce glue consumption($\approx 50g/m^2$), auto-adjust roller for different thickness, auto water spraying system, automatic glue feeding system, super high precision stainless steel rollers.

适用领域: 海绵行业、家具软体行业、包装行业、汽车行业
Industries: Foam, Furniture, Packaging, Automobile, etc



热熔胶机 HK-RRJ



样品展示 Sample



性能特点 Advantage:

- 这是一款针对弹簧床垫研发的喷胶设备, 能自动识别床垫大小, 省人工, 产能高, 每台机器上配置6把喷胶头, 可根据客户需求定制。

This is a glue equipment developed for spring mattresses. It can automatically identify the size of the mattress, save labor, and have high productivity. Each machine is equipped with 6 glue spray guns. Can be customized according to customer needs.

滚胶线示例图 Example of gluing line

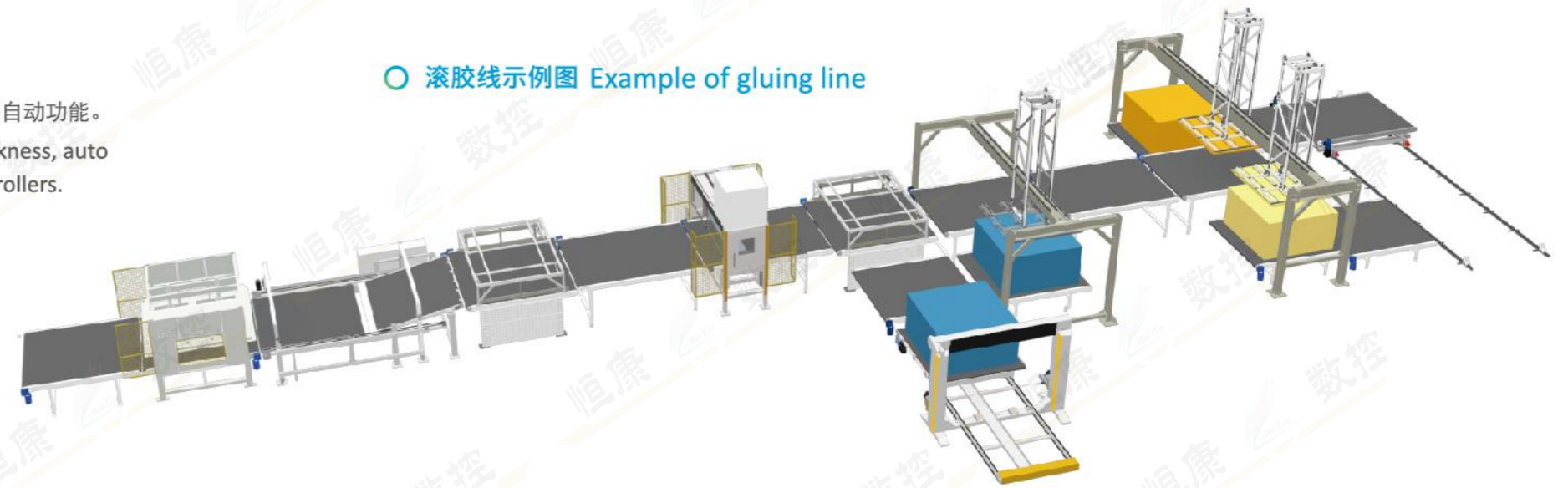



储运系统

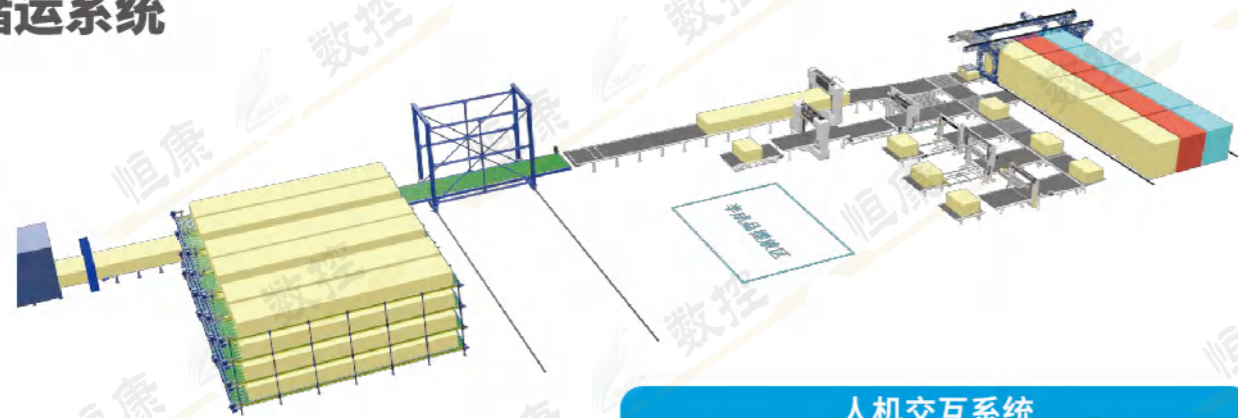

人机交互系统
Human-computer interaction system

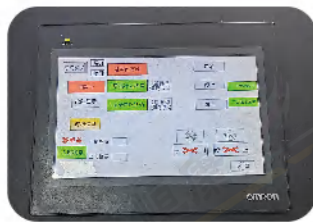

人机界面
Human-computer interaction



实时监控
Real-time monitoring



支持RFID、二维码
Support RFID, QR code

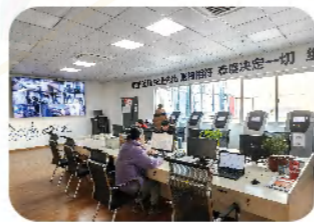

接入WMS、OMS系统
Access WMS, OMS system



立体海绵存储线 CNCHK-11

Intelligent Rack System

智能化程度高
High intelligence

节省人工
Save Labor

熟化快
Ripen quickly

节省空间
Save space

- 解决海绵发泡后的储运问题
- 定制化程度高
- 半自动、全自动控制
- 支持SAP/MES系统自动录入
- 实现自动进\出库
- 实时库位状态监控
- 自动计算熟化时间

- Rack for storing foam blocks after foaming
- Fully Customized Solutions
- Semi-automatic or fully automatic control
- Accessible to SAP/MES
- Automatic IN/OUT
- Real-time status monitoring
- Automatic calculation of curing time

